

Foam Sheathing Coalition

IRC Wall Bracing: A Guide for Builders, Designers and Plan Reviewers *With Supplemental Information on Appropriate Use of Foam Sheathing*

The requirement for bracing conventional wood frame dwellings is not new. For years, homes have been braced using a variety of techniques that have withstood the elements over time. Conventional wood frame dwellings must adequately brace against lateral (racking) forces due to wind and earthquakes. To achieve this structural safety objective, several wall bracing options and requirements are offered prescriptively in the International Residential Code (IRC) Section R602.10 Wall Bracing section, although the number of options and requirements has created confusion instead of a “simple-to-use” prescriptive code.

The main objective of this guide is to provide designers, code officials and builders a basic understanding of how to apply the IRC bracing provisions for code-compliant dwellings. A second objective is to demonstrate how the IRC bracing provisions can be used to create maximum value in a diverse housing market.

The guide is divided into four stand-alone sections; depending on your specific needs, refer to the relevant section:

- Section 1: Basic Concepts for Code-Compliant Wall Bracing
- Section 2: IRC Wall Bracing Requirements
- Section 3: ‘Beyond Code’ Bracing Solutions
- Section 4: Wall Bracing Options for Foam-Sheathed Wall Systems



For additional information and design details, refer to the [Supplement to IRC Wall Bracing Guide Design Examples](#).

Foam Sheathing Coalition (FSC)

Copyright 2006
Version 1.0

Table of Contents

Section 1: Basic Concepts for Code-Compliant Wall Bracing	1
<i>Why is Wall Bracing Needed?.....</i>	<i>1</i>
<i>How does Wall Bracing Work?.....</i>	<i>1</i>
<i>When Should I Consider Wall Bracing?.....</i>	<i>2</i>
<i>Definitions and Terms</i>	<i>2</i>
Section 2: IRC Wall Bracing Requirements.....	6
<i>Design Scope Limitations</i>	<i>6</i>
<i>Wall Bracing Methods</i>	<i>6</i>
<i>Applying the Code: Calculating the Amount of Bracing</i>	<i>9</i>
<i>Special Considerations.....</i>	<i>13</i>
Special Connection Requirements for Braced Wall Panels	13
Large Wall Openings & Prescriptive Narrow Braced Wall Panels.....	13
Garage Openings and Similar Applications	13
Fitting Large Openings within Code-Compliant Braced Wall Lines	15
<i>Applying the Code: Step by Step.....</i>	<i>17</i>
Section 3: ‘Beyond Code’ Bracing Solutions	18
<i>Custom Engineered Solutions.....</i>	<i>18</i>
<i>Engineered Standard Solutions (Examples & Concepts)</i>	<i>18</i>
Partial Credit for Narrow Braced Wall Panels.....	18
Interior Partition Walls as a Bracing Method	19
Reduce Bracing Amount for Braced Wall Line Spacing <35’	19
Allowance for Bracing Transfer.....	20
Allowance for > ±4’ limit for Offsets within a Braced Wall Line	21
<i>Proprietary Bracing Products</i>	<i>21</i>
Section 4: Wall Bracing Options for Foam-Sheathed Walls	22
<i>Why Use Foam Sheathing?.....</i>	<i>22</i>
<i>Meeting Energy Code Requirements</i>	<i>23</i>
<i>Which Bracing Method(s) to use with Foam Sheathing?</i>	<i>24</i>
<i>Examples</i>	<i>26</i>
<i>Interfaces between Materials</i>	<i>29</i>
Additional References	30
<i>Design Tools and Resources:.....</i>	<i>30</i>
<i>Metal Bracing:</i>	<i>30</i>
<i>Proprietary Bracing Products:</i>	<i>30</i>
Attachment A: Wall Bracing Design and Plan Check Worksheet	31

List of Tables and Figures

Tables

Table 1: Common IRC Bracing Methods and Requirements7
Table 2: Minimum Braced Wall Panel Lengths for Continuous Wood Structural Sheathing Braced Walls 8
Table 3a: Minimum Wall Bracing Amounts 11
Table 4: Effective Brace Lengths for Brace Segments <48" 19
Table 5: Functions of Foam Sheathing in Above-Grade Residential Walls..... 23
Table 6: Common IRC Wall Bracing Methods using Foam Sheathing 24

Figures

Figure 1: Wall Bracing and Racking Forces..... 1
Figure 2: Braced Wall Line Offset Limitations 4
Figure 3: Use of Interior Braced Wall Lines 4
Figure 4: Examples of Bracing Methods 5
Figure 5: Corner Framing for Continuous Structural Sheathing..... 9
Figure 6: Bracing Options for Garage Door and other Large Openings in a Braced Wall Line 14
Figure 7: Example of Portal Frame Garage Opening Construction (HUD, 1998) 15
Figure 8: Limits for Large Openings in Braced Wall Lines..... 16
Figure 9: Bracing Transfer 20
Figure 10: Illustration of Bracing Methods with Foam Sheathing 25

Section 1: Basic Concepts for Code-Compliant Wall Bracing

Why is Wall Bracing Needed?

Wall bracing provides racking resistance against horizontal (lateral) racking loads from wind and earthquakes and prevents the wall studs from distorting in the plane of the wall (racking) in “domino fashion” and, thus, prevents building collapse. As shown in **Figure 1**, racking loads on a building are considered to act separately in two perpendicular plan directions (i.e., N-S and E-W or front-rear and left-right). At least two wall lines parallel to each plan direction (and on opposite sides of the building) must be designed to resist potential racking loads.

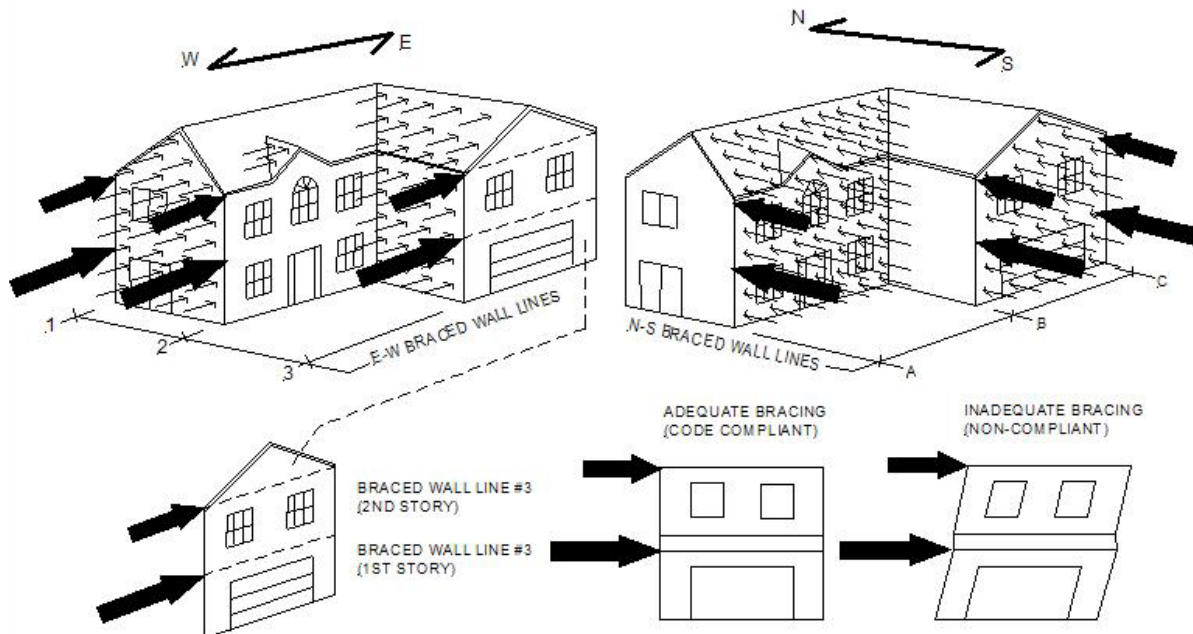

Figure 1: Wall Bracing and Racking Forces

How does Wall Bracing Work?

When bracing a wall, code-compliant bracing elements or “braced wall panels¹” are located in required amounts on wall lines that are required to resist racking loads, known as “braced wall lines”. For simplicity, building codes have developed prescriptive bracing strategies that look only at designated “braced wall lines” and individual “braced wall panels” on those braced wall lines; in reality, walls act as a system in resisting racking forces, where nearly every component and wall segment provides some racking resistance.

The entire building - wall, floor and roof assemblies - interacts to distribute racking loads. For example, standard interior partition walls also contribute to racking resistance, although the IRC does not explicitly consider their contribution. In addition, roof and floor diaphragms help distribute racking loads from walls with less bracing to those with more bracing. By considering only designated braced wall lines without considering the building system as a whole, the IRC bracing provisions generally result in conservative solutions. For example, if an individual braced wall line (e.g., garage opening wall) is deemed ‘non-compliant’ when strictly applying the IRC, it

¹ See Definitions and Term, page 2 for details

may actually be acceptable from the standpoint of the entire building system. To make practical use of these building system realities requires solutions that go beyond the simple assumptions that a prescriptive code is based upon. Refer to Section 3: ‘Beyond Code’ Bracing Solutions and the Additional Reference section for additional support and resources.

Each braced wall line requires different amounts of bracing depending on the individual share of the racking load acting on the building as a whole (*Figure 1*). The amount of bracing required for a given wall line depends on:

Design Factor	Comment
The design wind or earthquake load (magnitude of hazard).	Buildings in higher hazard areas with large design wind speeds or earthquake ground motions experience greater potential racking load.
The size of the building and how many stories are supported by a braced wall line.	Walls supporting multiple stories have greater racking loads than those supporting only a roof. Lower story walls serve to resist an accumulation of lateral load from upper story levels that must be passed down to the foundation and then to earth, in much the same way that gravity (vertical) loads have a load path.
The spacing between braced wall lines.	For buildings that have widely-spaced wall lines and large interior open areas, the racking load shared by each wall line is increased relative to a building that has many closely-spaced wall lines in each plan direction.
The type or method of wall bracing used (strength of brace).	The method of bracing will determine how much bracing is needed. Some methods allow for less bracing and narrower braced wall panels in comparison to other methods that require more bracing and wider braced wall panels to achieve equivalent performance (i.e., racking resistance meeting or exceeding racking load).

When Should I Consider Wall Bracing?

The design factors (see above) affect the amount of space available on a given wall and the quantity when placing windows, doors and other non-structural sheathing products such as insulating foam sheathing.



Always consider wall bracing as early as possible in the design process.

In the planning stages, a simple plan adjustment often makes the difference between an efficient, code-compliant plan and one that is inefficient or non-compliant. In some cases, an engineered solution may be required where the IRC prescriptive solutions are insufficient for the architectural requirements. Refer to Section 3: ‘Beyond Code’ Bracing Solutions for additional support.

Definitions and Terms

The following concepts and definitions are fundamental to understanding and applying the IRC bracing requirements R602.10.

Braced Wall Line (R602.10.1) - Walls that are braced to resist racking are known as braced wall lines. Essentially all exterior walls are considered to be braced wall lines and are required to be properly braced with braced wall panels. Although not always required, interior walls may also be used as braced wall lines. A braced wall line can have limited offsets as shown in *Figure 2* and still be considered a single braced wall line. When an offset does not comply with those limits (i.e., offset exceeds ±4’ or 8’ in total), the wall lines to either side of the offset are required to be considered separate braced wall lines. In this

manner, offsets can affect braced wall panel location and, thus, the layout of openings for windows and doors in a series of braced wall lines on a given building side (elevation).

Braced Wall Line Spacing (R602.10.1.1) - Braced wall line spacing establishes the amount of racking load that must be resisted by the two or more parallel braced wall lines in each plan direction (see *Figure 1*). The racking load must be resisted by incorporating an adequate amount of braced wall panels in each braced wall line. Therefore, bracing amounts are dependent on the spacing between parallel braced wall lines (see *Figure 1*). This consideration influences the space that is available for wall openings on exterior walls, which may require using interior braced wall lines to help share the bracing load (e.g., reduce the braced wall line spacing) as shown in *Figure 3*. In Section 2 of this guide, minimum required bracing amounts have been tabulated based on braced wall lines spaced apart by 35' up to a maximum 50' as permitted by the IRC.

: The interior braced wall line in *Figure 3* is subject to the same braced wall panel location requirements that apply to exterior braced wall lines. While the amount of bracing required should be determined using the length of the wall as though it extends entirely between opposite sides of the building as shown in *Figure 3*, the interior braced wall line itself need not extend the entire distance. Determination of bracing amount is addressed in Section 2 of this guide.

Braced Wall Panel (R602.10.1) - A braced wall panel is a section of a braced wall line that is braced with a code-compliant bracing method (e.g., let-in brace, a wood structural panel, or other bracing methods) (See *Figure 4*). Braced wall panels must meet minimum width requirements (length of wall covered) to count towards the required bracing amounts. The minimum widths required for braced wall panels of the various bracing methods constrain the layout and spacing of wall openings in a code-compliant braced wall line. While braced wall panels that are narrower than allowed still contribute to bracing, this contribution may only be considered through an engineered design or supplemental solutions. (See Section 3: 'Beyond Code' Bracing Solutions)

Braced Wall Panel Location (R602.10.1) - In addition to being used to meet minimum bracing amounts, the location of braced wall panels on braced wall lines must meet additional constraints (see *Figure 4*):

- (1) Braced wall panels must be spaced no greater than 25' OC along a braced wall line, and.
- (2) Braced wall panels must begin no more than 12.5' from the end of a braced wall line (usually defined by an inside or outside building corner).

: For the continuous wood structural sheathing method (IRC Section R602.10.5), a minimum 2' panel must be located on both sides of corners at the ends of the braced wall line (see *Figure 4c*).

: Notice that *Figure 4c* shows that different bracing methods may be used on different braced wall lines of a given building. In addition, certain bracing methods may be substituted for another within a portion of given braced wall line. This consideration is important for design flexibility to create code-compliant buildings that maximize value of other building objectives (e.g., cost-effectiveness, energy-efficiency, weather-resistance, etc.). Additional guidance on this topic is provided as appropriate in later sections.

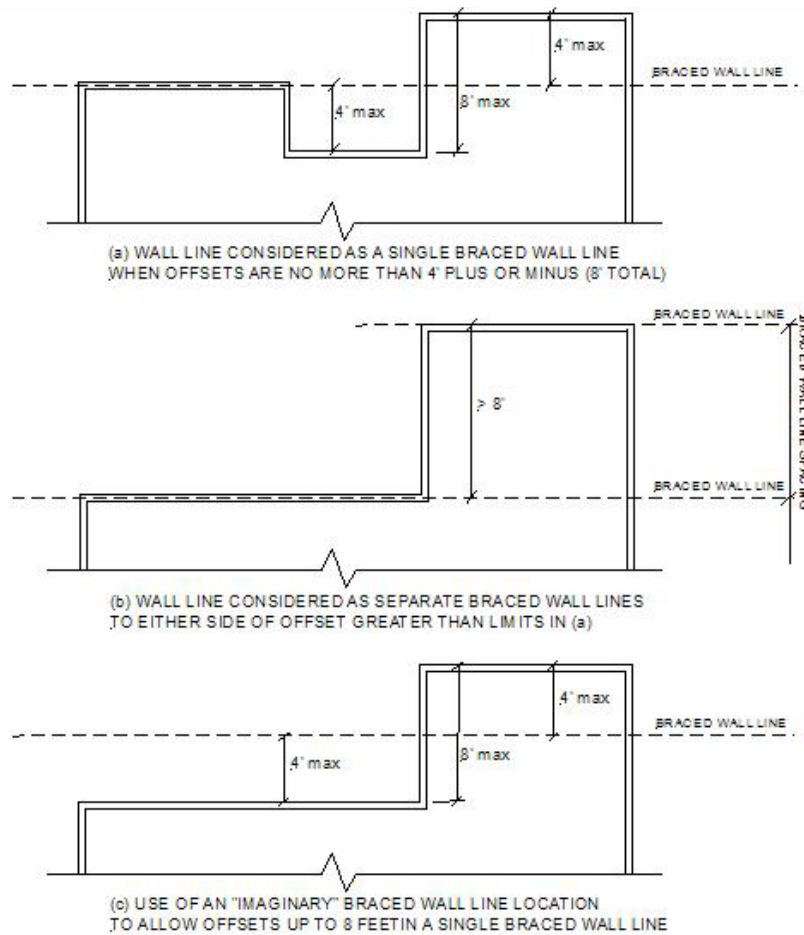
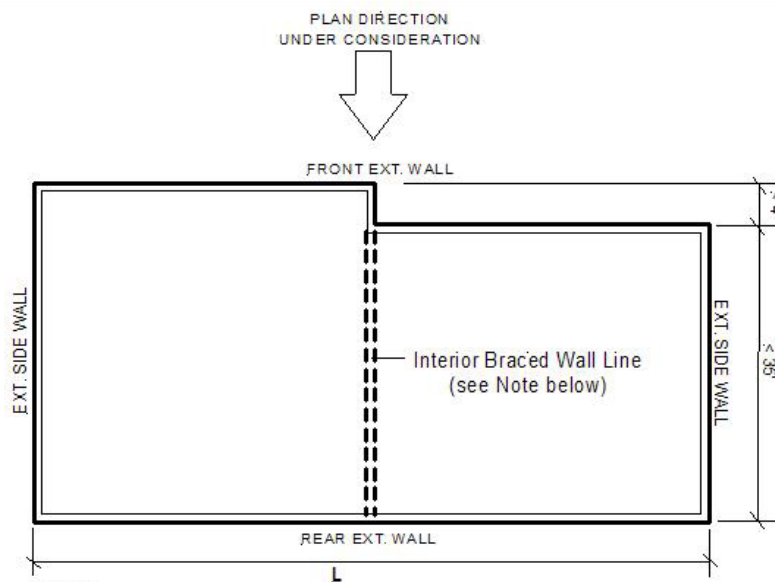
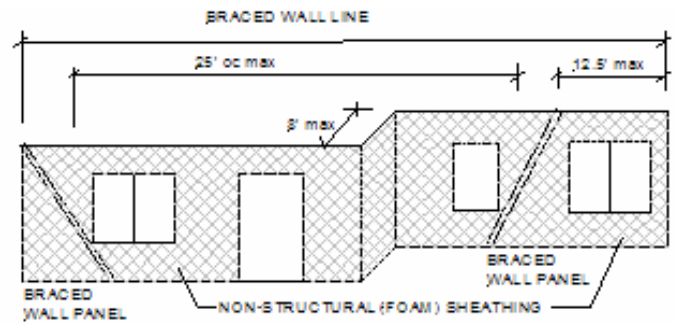

Figure 2: Braced Wall Line Offset Limitations



NOTE:
 When L is greater than 50 feet, an interior braced wall line is required. When L is greater than 35 feet, but less than 50 feet, then the interior braced wall line is optional, however, its use will allow reduced bracing on parallel exterior walls in the same plan direction. When L is 35 feet or less, an interior braced wall line is not required.

Figure 3: Use of Interior Braced Wall Lines



(a) METHOD 1 (LET-IN) WALL BRACING

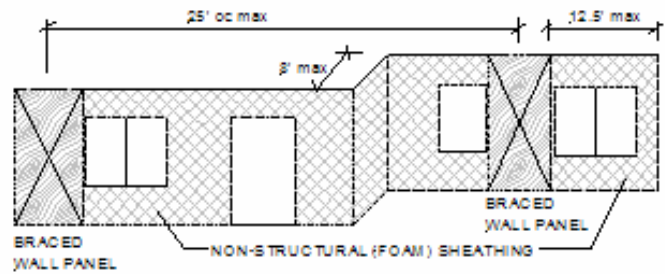

(b) METHOD 3, 4, OR 5 WALL BRACING

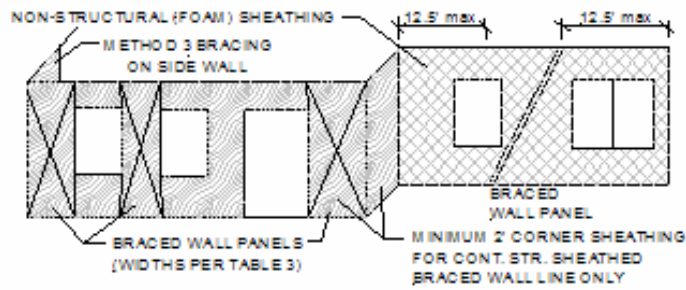

(c) CONTINUOUS STRUCTURAL SHEATHING (LEFT FACING WALL), METHOD 1 ON RIGHT FACING WALL, AND METHOD 3 ON SIDE WALL (FACING WALLS TREATED AS SEPARATE BRACED WALL LINES)

Figure 4: Examples of Bracing Methods

Section 2: IRC Wall Bracing Requirements

Design Scope Limitations



This guide is limited to the following use conditions:

- *International Residential Code*, 2000 through 2006 Editions²
- One- and two-family dwellings³
- Conventional wood frame construction
- Wind speed of less than 100 mph (gust) per IRC Section R301.2 in Seismic Design Categories A/B (See Table 3a)
- Wind speed of less than 110 mph (gust) per IRC Section R301.2 in Seismic Design Category C (See Table 3b)
- Seismic Design Category (SDC) of A/B/C per IRC Section R301.2³

By limiting the scope to lower wind and seismic conditions, the IRC bracing provisions are greatly simplified, but still cover the majority of conditions in the United States. To identify your specific seismic and wind speed location, see (A)Figure R301.2(2) Seismic Design Categories and (B)Figure 301.2(4) Basic Wind Speeds for 50 year Mean Recurrence Interval in IRC2003.

While this guide addresses principles that also apply to buildings in more hazardous areas, the exact bracing requirements are different. Refer to additional requirements in the IRC for conditions outside the scope of this guide.

Wall Bracing Methods

Table 1 summarizes the most commonly used IRC bracing methods.



Remember that these are the basic 'bracing building blocks' - a variety of these methods may be used to design and construct a code-compliant braced wall or building.

² This guide is primarily based on IRC 2003 but is also applicable to IRC 2000 provided requirements for interior braced wall lines and braced wall line spacing are ignored. Any additional provisions of the IRC 2006 are specifically noted in this guide.

³ Townhouses in SDC C are excluded from this guide because additional seismic design limitations in IRC Section R301.2.2 apply and are outside the scope of this guide. However, those limitations may be waived by local code amendment or by approved design given that the same structural and bracing requirements must be satisfied regardless of a dwelling's classification as single-family detached or single-family attached (townhouse) construction. In fact, the limitations of IRC Section R301.2.2 for building irregularities (constraints on configuration) do not apply to conventional construction in IBC Section 2308 until the next higher seismic design category, SDC D.

Table 1: Common IRC Bracing Methods and Requirements
(based on IRC Section R602.10.1, R602.10.3-6)

Bracing Method ^a	Braced Wall Panel Minimum Width ^b
TRADITIONAL BRACING METHODS	
METHOD 1: 1x4 wood let-in brace or approved metal brace	Brace angle must be at least 45 degrees and not more than 60 degrees from horizontal. ↻: Each such brace counts as a “braced wall panel”. Approved metal braces should be specified and installed in accordance with the manufacturer’s data and code evaluation report
METHOD 3: Wood structural panels METHOD 4: Fiberboard	48” minimum ↻: Braced wall panels that are 48” wide or more count toward required bracing amounts; multiple sheathing panels may be used to form an individual braced wall panel.
METHOD 5: Gypsum board	96” minimum (single side) 48” minimum (both sides) ↻: For ‘both sides’ application, braced wall panels 48” wide or more count toward required bracing amounts; for ‘single side’ application, braced wall panels 96” wide or more count toward required bracing amount in accordance with actual length.
SUPPLEMENTAL BRACING METHODS	
Continuous wood structural panel sheathing (R602.10.5) ^c	24” and greater - see Table 2 (braced wall panels complying with minimum width requirements of Table 2 count toward required bracing amount and vary in accordance with the height of an adjacent window or door opening) ↻: Similar to Method 3 but requires all sheathable areas of a braced wall line to be sheathed, including areas above and below wall openings; minimum 2’ wide panels are required at each end of the braced wall line at corners. See Figure 4c and Figure 5.
Alternate braced wall panels (R602.10.6) (Section R602.10.6.1 in IRC 2006)	32” minimum ↻: Each 32” alternate braced wall panel may be substituted for a 48” braced wall panel of another bracing method. ↻: Similar to Method 3 with additional sheathing nails but requires using hold-down brackets at each end of the braced wall panel directly anchored to the foundation; limited to 1-story and first floor of a 2-story application)
R602.10.6.2 Alternate braced wall panel adjacent to a door or window opening (Portal Frame) (IRC 2006 only)	16” minimum (supporting one story); 24” minimum (supporting two stories) ↻: Each such panel may be substituted for a minimum 48” braced wall panel of any one of the other bracing methods listed above. ↻: This method requires special wall framing details, connection hardware, and sheathing nailing patterns which are addressed in the IRC 2006. A variation of this method without using hold-down brackets is also found in Section R602.10.5 of the IRC 2006 (footnote ‘c’ of Table R602.10.5) - also refer to footnote ‘c’ below.

Notes:

- a. Refer to IRC Section R602.10.3, R602.10.5, and R602.10.6 for important installation requirements, material thickness requirements, and details related to fastening for each bracing method.
- b. Refer to Section 3: ‘Beyond Code’ Bracing Solutions for alternative minimum braced panel widths.
- c. Note that the IRC 2003 and 2006 versions of Section R602.10.5 include language not found in the IRC 2000 which requires correction and/or clarification. In particular, language implying that “all walls” of a building must be continuously sheathed should be deleted for reason of inconsistency with the original data substantiating the approval of this method in the IRC 2000. Second, the amount of sheathing required at the ends of such a fully-sheathed wall should be clarified as 2’ minimum length of full-height structural sheathing (applied to both sides of the corner per Figure R602.10.5 or Figure 5 in this guide). These same concerns also apply to the use of the portal framing method of Section R602.10.6.2 of the IRC 2006 and as modified in footnote ‘c’ of Table R602.10.5 (or Table 2 of this guide). At the time of this writing, several states and localities have already made such corrections or clarifications through their local code adoption processes and several similar ICC code proposals are pending consideration in the 2006/2007 code development hearing cycle.

Table 2: Minimum Braced Wall Panel Lengths for Continuous Wood Structural Sheathing Braced Walls (based on IRC Table R602.10.5)

Largest Adjacent Opening Height (inches)	Minimum Braced Wall Panel Length (inches)		
	8-ft Wall	9-ft Wall	10-ft Wall
102	N/A	N/A	38
99	N/A	N/A	37
96	N/A	N/A	36
93	N/A	35	35
90	N/A	34	34
87	N/A	33	33
84	32	32	32
81	30	30	30
78	29	29	30
75	28	28	30
72	27	27	30
69	26	27	30
66	25	27	30
63	24	27	30

Notes:

- a. 'N/A' indicates that opening height exceeds limits permitted for use with IRC Section R602.10.5.
- b. For continuous structural sheathed braced wall lines containing only garage openings and which support a light frame roof only, braced panel widths shall be permitted to have a 4:1 height-to-width ratio (with height being measured from the bottom to the top of the braced wall panel). Minimum panel width shall not be less than 24 inches.

⚠: The 3 psf roofing dead load limit in the related IRC Table R602.10.5 footnote is not intended to apply in SDC A/B/C. Actually, heavier roofing is a benefit in regions where wind governs wall bracing design.

- c. Walls on either or both sides of openings in garages shall be permitted to be built in accordance with Section R602.10.6.2 and Figure R602.10.6.2 (IRC 2006) except that a single bottom plate shall be permitted and two anchor bolts shall be placed at 1/3 points. In addition, tie-down devices shall not be required and the vertical wall segment shall have a maximum 6:1 height-to-width ratio (with height being measured from top of header to the bottom of the sill plate). This option shall be permitted for the first story of two-story applications in Seismic Design Categories A through C.

⚠: The requirement for “fully-sheathed dwelling” in the related IRC 2006 Table R602.10.5 note is not required in the note above for reasons given in note ‘c’ of Table 1.

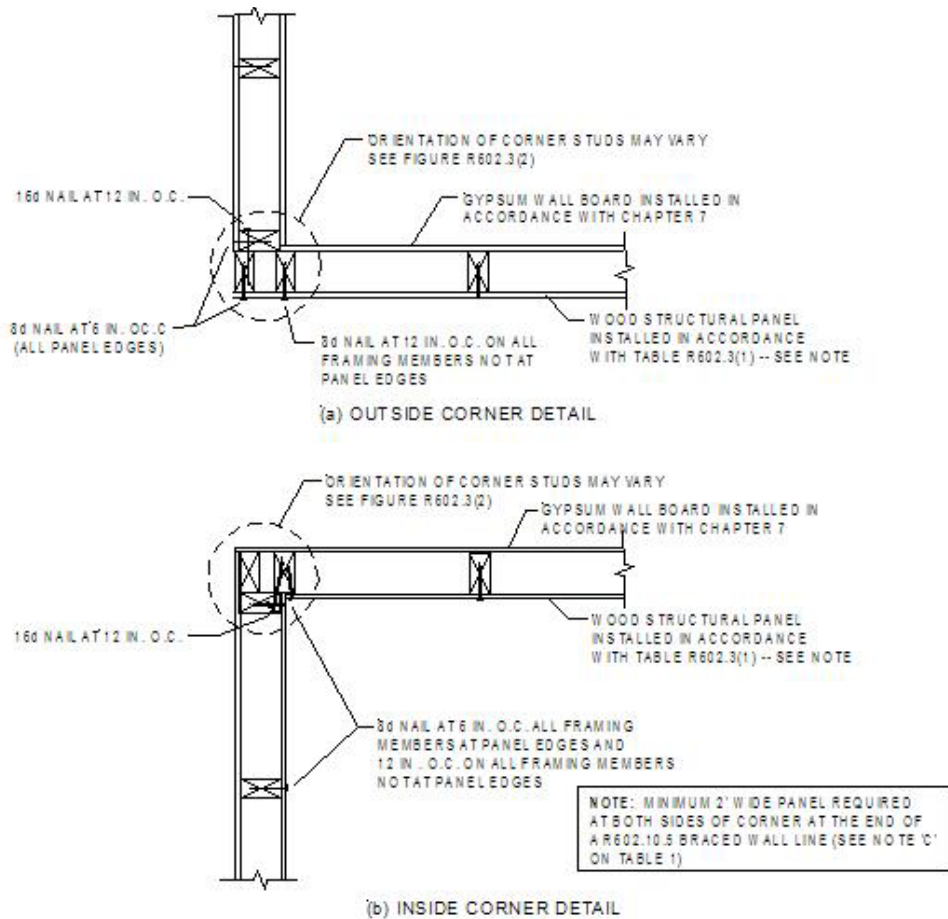

Figure 5: Corner Framing for Continuous Structural Sheathing
(Based on IRC Figure R602.10.5)

Applying the Code: Calculating the Amount of Bracing

The minimum required wall bracing amounts for commonly-used bracing methods are shown in *Tables 3a and Table 3b*.

- *Table 3a* applies to typical hazard conditions found in most regions of the United States.
- *Table 3b* addresses a moderate hazard condition. These tables are based on Table R602.10.1 of the IRC plus some “user-friendly” improvements such as pre-calculating bracing amounts for:
 - 1) Permitted braced wall line spacings, and
 - 2) Continuous structural panel sheathing method of Section R602.10.5.



Refer to Section 1 (page 2) of this guide for important information on the following definitions: *braced wall line*, *braced wall panel*, *braced wall panel location*, and *braced wall line spacing*. These definitions involve concepts and requirements that are very important to a code-compliant and efficient application of required wall bracing amounts on a given braced wall line or building plan.

For many braced wall lines, Method 1 let-in bracing may be the simplest method to use in terms of determining and applying required bracing amounts. The amount of bracing is simply determined by the spacing of code compliant 1x4 wood let-in or approved metal braces along a braced wall line (see Figure 4a). As shown in *Table 3a* and *Table 3b*, the spacing of Method 1 braces along a braced wall line decreases from 25'OC as the spacing between braced wall lines increases beyond 35'OC. This requirement increases the racking strength of a Method 1 braced wall line to offset the added racking load from a greater than 35' spacing between braced wall lines (refer to IRC Section R602.10.1.1, exception statement). Also note that a Method 3 brace may be used in place of any required Method 1 brace on a given braced wall line based on the principle of equivalence (i.e., Method 3 panel brace is at least as strong as a Method 1 let-in brace). Finally, the use of Method 1 bracing is limited to one- and two-story construction in *Table 3a* and one-story construction in *Table 3b*.

For the other common bracing methods featured in *Table 3a* and *Table 3b*, bracing amounts are given as the minimum percentage of braced wall line length that must be braced by code-compliant braced wall panels (see *Table 1* and *Figure 4b and c*).

To determine the minimum required length of bracing for a given braced wall line, use the following simple equation:

$$\begin{aligned} & \text{Minimum Required Length of Braced Wall Panels} \\ & = [\text{Braced wall line length}] \times [(\text{Percentage from Table 3A or B})/100] \quad \text{Eq. 1} \end{aligned}$$

Example:

Given: 25% amount of bracing required for a braced wall line (Table 3a or 3b)
32' braced wall line length

Solution: $[32'] \times [25\% / 100] = 32' \times 0.25 = 8'$

Therefore, a total of 8' of braced wall panels is the minimum required amount of bracing for this example braced wall line (i.e., two 4' braced wall panels). Depending on braced wall panel location on the braced wall line, an additional braced wall panel may be required.

*Table 3a: Minimum Wall Bracing Amounts
for Seismic Design Categories A/B and Wind Speed of ≤ 100 mph^{a,b,c}
(based on IRC Table R602.10.1 and Sections R602.10.1.1, R602.10.5, and R602.10.6)*

Braced Wall Line Condition	Braced Wall Line Spacing (feet)	Method 1	Method 3	Method 4	Method 5		R602.10.5 Continuous Structural Sheathing ^d	
					One Side ^e	Both Sides	Case A	Case B
					Supporting Roof Only	≤35	25'OC	16%
	40	22'OC	18%	18%	36%	18%	16%	15%
	45	20'OC	21%	21%	42%	21%	19%	17%
	50	18'OC	23%	23%	46%	23%	20%	19%
Supporting Roof plus One Story	≤35	25'OC	16%	25%	50%	25%	14%	13%
	40	22'OC	18%	29%	58%	29%	16%	15%
	45	20'OC	21%	32%	64%	32%	19%	17%
	50	18'OC	23%	36%	72%	36%	20%	19%
Supporting Roof plus Two Stories	≤35	NP	25%	35%	70%	35%	23%	20%
	40	NP	29%	40%	80%	40%	26%	23%
	45	NP	32%	45%	90%	45%	29%	26%
	50	NP	36%	50%	100%	50%	32%	29%

Notes:

NP = not permitted

- a. Interpolation between braced wall line spacing amounts is permissible.
- b. Table applies to stud walls up to 10' tall. For walls 12' tall, multiply bracing amounts by 1.2 (IRC Section 301.3).
- c. For Method 1 bracing, braces shall be located no more than 12.5' from the ends of a braced wall line and shall be spaced along a braced wall line as shown in the table. For the other methods, braced wall panels shall not be spaced greater than 25' OC and also shall be located no more than 12.5' from the ends of a braced wall line. However, for R602.10.5 continuous structural panel sheathing, a minimum 2' length of full-height sheathing is required at the corners per *Figure 4c*. Refer to *Table 1* for minimum lengths of individual braced wall panels and other requirements for each bracing method.
- d. Case A applies to braced wall lines with *maximum opening height* not exceeding 86" (8' stud walls), 95" (9' stud walls) or 102" (10' stud walls). Case B applies to braced wall lines with maximum opening height not exceeding 65" (8' stud walls), 74" (9' stud walls) or 80" (10' stud walls). The *maximum opening height* in a continuous structural sheathed braced wall line is the rough opening with the largest height measured from the bottom of the rough opening to the top of the rough opening.
- e. Method 5 (one side) bracing amounts are doubled relative to Method 5 (both sides) to account for the difference in strength of the two applications of Method 5 bracing. This consideration was overlooked in development of the IRC wall bracing provisions, but is included in the IBC Section 2308 wall bracing provisions.

Table 3b: Minimum Wall Bracing Amounts
 for Seismic Design Category C and Wind Speed of <110 mph^{a,b,c}
 (based on IRC Table R602.10.1 and Sections R602.10.1.1, R602.10.5, and R602.10.6)

Braced Wall Line Condition	Braced Wall Line Spacing (feet)	Method 1	Method 3	Method 4	Method 5		R602.10.5 Continuous Structural Sheathing ^d	
					One Side ^e	Both Sides	Case A	Case B
Supporting Roof Only	≤35	25'oc	16%	25%	50%	25%	14%	13%
	40	22'oc	18%	29%	58%	29%	16%	15%
	45	20'oc	21%	32%	64%	32%	19%	17%
	50	18'oc	23%	36%	72%	36%	20%	19%
Supporting Roof plus One Story	≤35	NP	30%	45%	90%	45%	27%	24%
	40	NP	34%	51%	NP	51%	31%	27%
	45	NP	39%	58%	NP	58%	35%	31%
	50	NP	43%	64%	NP	64%	39%	34%
Supporting Roof plus Two Stories	≤35	NP	45%	60%	NP	60%	41%	36%
	40	NP	51%	69%	NP	69%	47%	41%
	45	NP	58%	77%	NP	77%	53%	46%
	50	NP	64%	86%	NP	86%	59%	51%

Notes:

NP = not permitted

- a. Interpolation between braced wall line spacing amounts is permissible
- b. Table applies to stud walls up to 10' tall. For walls 12' tall, multiply bracing amounts by 1.2 (IRC Section 301.3).
- c. For Method 1 bracing, braces shall be located no more than 12.5' from the ends of a braced wall line and shall be spaced along a braced wall line as shown in the table. For the other methods, braced wall panels shall not be spaced greater than 25' OC and also shall be located no more than 12.5' from the ends of a braced wall line. However, for R602.10.5 continuous structural panel sheathing, a minimum 2' length of full-height sheathing is required at the corners per *Figure 4c*. Refer to *Table 1* for minimum lengths of individual braced wall panels and other requirements for each bracing method.
- d. Case A applies to braced wall lines with *maximum opening height* not exceeding 86" (8' stud walls), 95" (9' stud walls) or 102" (10' stud walls). Case B applies to braced wall lines with maximum opening height not exceeding 65" (8' stud walls), 74" (9' stud walls) or 80" (10' stud walls). The *maximum opening height* in a continuous structural sheathed braced wall line is the rough opening with the largest height measured from the bottom of the rough opening to the top of the rough opening.
- e. Method 5 (one side) bracing amounts are doubled relative to Method 5 (both sides) to account for the difference in strength of the two applications of Method 5 bracing. This consideration was overlooked in development of the IRC wall bracing provisions, but is included in the IBC Section 2308 wall bracing provisions.



Depending on length of a braced wall line, a minimum of one braced wall panel is required in each braced wall line and, usually, a minimum of two panels are required for each building side at each story level.

Special Considerations

Special Connection Requirements for Braced Wall Panels

The following lists some of the special connection requirements for braced wall panels (refer to IRC Section R602.10.8):

- Connect sole plates at braced wall panel locations to wood floor framing in accordance with Table R602.3(1) Fastener Schedule or to foundations per IRC Section R403.1.6 Foundation Anchorage using nails or anchor bolts as required.
- Attach brace panels or braces to wall framing in accordance with bracing method descriptions per IRC Section R602.10.3.
- Support and attach all horizontal and vertical joints of sheathing used as braced wall panels to wall framing or blocking per IRC Section R602.10.7.
 - ↳: IRC Section R602.10.7 permits use of unblocked horizontal joints in panel sheathing. Because this reduces the braced wall panel strength by approximately one-half and is not accounted for with increased bracing amounts, it is not recommended for braced wall panel construction. Use unblocked horizontal sheathing joints only where sheathing is not required to meet minimum bracing amounts.
- Adhesive (glue) attached braced wall panels are not permitted in SDC C per IRC Section R602.10.11.2.

Large Wall Openings & Prescriptive Narrow Braced Wall Panels

With some limitations, code-compliant garage opening walls with narrow braced wall panels, 'great room' walls with large openings and other similar conditions can be constructed using the IRC wall bracing provisions. See Section 3: 'Beyond Code' Bracing Solutions for additional information.

Garage Openings and Similar Applications - As shown in *Figure 6*, four prescriptive options are available in the IRC to address large openings in braced wall lines with narrow braced wall panels, such as garage door openings that cannot be otherwise braced using traditional methods (e.g., 48" wide braced wall panels).

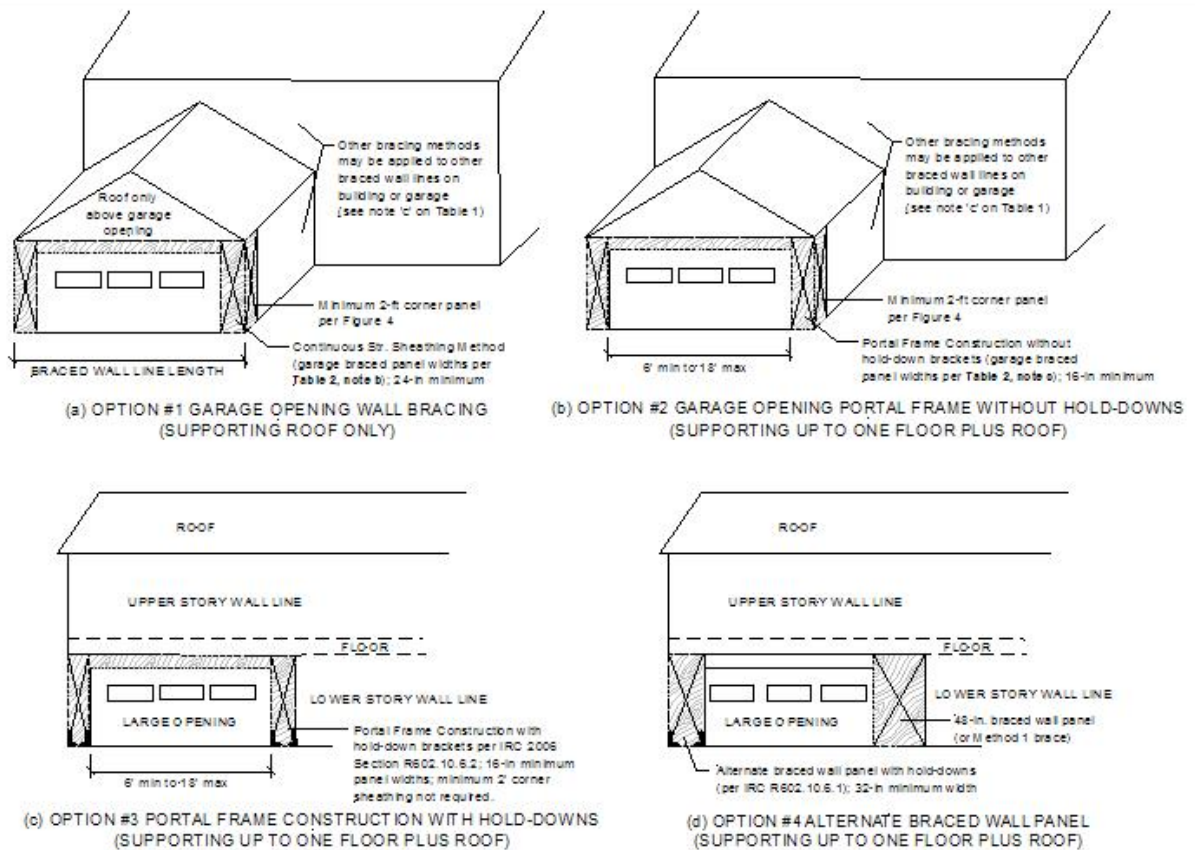

Figure 6: Bracing Options for Garage Door and other Large Openings in a Braced Wall Line

Option #1: A special exception provides for narrow braced panel widths used in garage opening walls per IRC Section Table R602.10.5, footnote b (see Table 2, note b in this guide). Restrictions include:

- Attached or detached garages only.
- Single story; garage opening braced wall line supports a roof only.
- Garage opening wall is braced with the continuous structural sheathing method (including 2' minimum corner panels at ends of continuous structural sheathed garage opening wall per *Figure 6a*).

Option #2: Use a portal frame without hold-down brackets that permits braced wall panels as narrow as 16" wide per IRC 2006 Table R602.10.5, note c (see Table 2, note c in this guide). Restrictions include:

- Attached or detached garages only.
- Two story; garage opening portal frame supports no more than roof plus one floor.
- 2' minimum corner panels at ends portal frame per *Figure 6b*.

🔗: An example of portal frame construction without hold-down brackets is shown in Figure 7 for illustration purposes only. Refer to IRC 2006 for specific code-compliant requirements.

Option #3: Use a portal frame with hold-down brackets (*Figure 6c*) that permits braced wall panels as narrow as 16" wide (supporting roof only) or 24" wide (supporting roof plus one floor) per IRC 2006 Section R602.10.6.2. Restrictions include:

- Any large opening with header span of 6' to 18' (not just limited to garage openings).
- Two story; garage opening portal frame supports no more than roof plus one floor.

- Portal frame braced wall panels must be directly anchored to foundation with hold-down straps (use on lowest story only).

Option #4: Use 32” wide alternate braced wall panels with hold-down brackets (*Figure 6d*) per IRC R602.10.6 (IRC 2006 Section R602.10.6.1). Restrictions include:

- Can be substituted for any 48” wide panel (counts as 4’ of braced wall panel length for bracing amount) - not just limited to garage openings.
- Requires sheathing on both sides of braced wall panel when supporting roof plus one floor; sheathing on one side applies only when supporting roof only.
- Alternate braced wall panels must be directly anchored to foundation with hold-down anchors or straps (use on lowest story only)

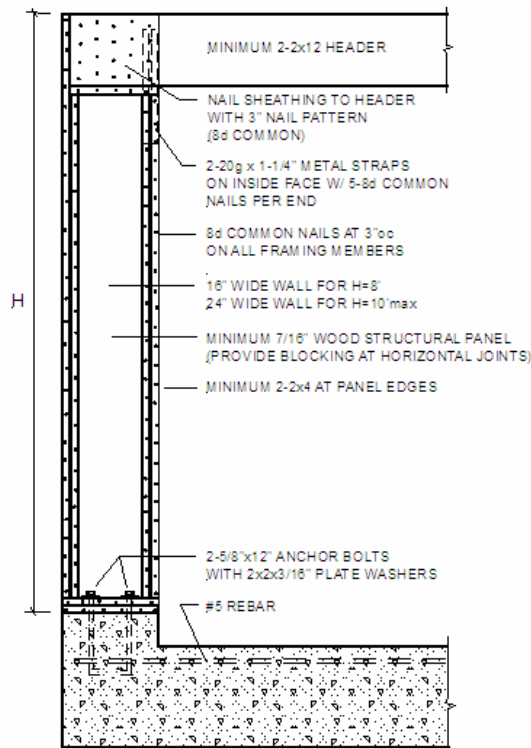

Figure 7: Example of Portal Frame Garage Opening Construction (HUD, 1998)
 [refer to Table 1 for important information and to IRC 2006 for code-approved construction details]

Fitting Large Openings within Code-Compliant Braced Wall Lines - Frequently a design requires a large opening within or at the ends of braced wall lines, especially for entry foyers and ‘great rooms’. For the limits shown in *Figure 8*, the IRC wall bracing provisions can accommodate these types of conditions in code-compliant braced wall lines.

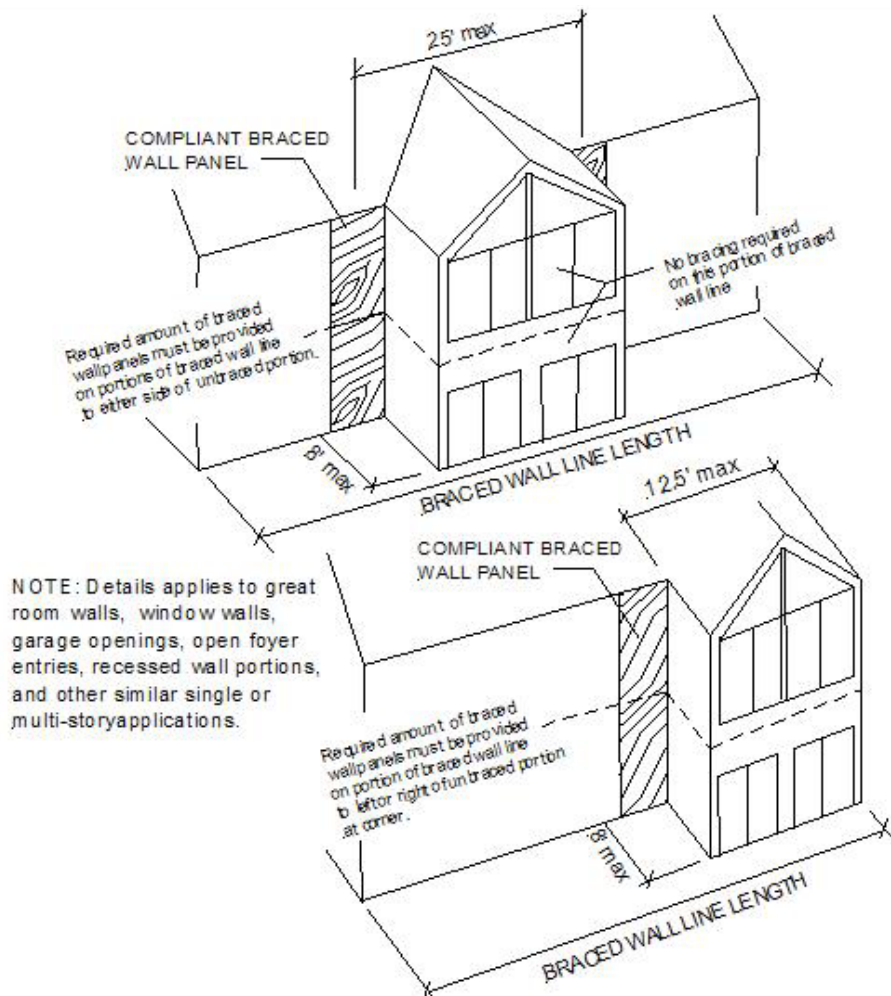

Figure 8: Limits for Large Openings in Braced Wall Lines

Applying the Code: Step by Step

Applying the wall bracing provisions of the IRC to a building plan is best approached in a stepwise fashion. Follow these steps, capturing your information on the attached worksheet (see Appendix A) to define the required bracing for your ‘braced wall line’.



For additional information and design details, refer to the [Supplement to IRC Wall Bracing Guide Design Examples](#).

- Step 1: Identify braced wall lines on a preliminary plan (e.g., check offsets and label separate braced wall lines on each side of the building).
- Step 2: For each plan direction (N-S and E-W) and story level, determine the spacing between exterior and interior braced wall lines.
- Step 3: Select a bracing method for each braced wall line and determine required bracing amounts for each braced wall line (see *Table 3a or 3b*).
- Step 4: Determine the bracing amount provided by code-compliant braced wall panels (see *Table 1*) on each braced wall line and verify that the minimum required bracing amount from Step 3 is met or exceeded.
- Step 5: Verify braced wall panel spacing limit (e.g., maximum 25' OC) and corner distance (e.g., braced wall panel starts no more than 12.5' from the end of a braced wall line) are met for each braced wall line. Remember also that a minimum 2' wide panel is required on both sides of corners at the ends of a continuous structural sheathing braced wall line per IRC R602.10.5.
- Step 6: If the bracing requirements are NOT met after completing Step 4 and/or Step 5, use a ‘trial and error’ approach to find a compliant solution for each braced wall line. Options include:
 - Reduce or shift braced wall line openings to allow space for required braced panel widths, location and amount.
 - Reduce spacing between braced wall lines (or use interior braced wall lines) to reduce the minimum required bracing amount.
 - Limit braced wall line offsets so that separate offset wall lines on a building side (elevation) may be considered as one braced wall line which eliminates the need for additional braced wall panels within 12.5' of the end of each separate braced wall line on a given building side.
 - Select a different bracing method that allows narrower braced panel width to be used (*Table 1*) and/or a reduced bracing amount.
 - Use a supplemental solution (See Section 3: ‘Beyond Code’ Bracing Solutions).

Section 3: 'Beyond Code' Bracing Solutions

When the IRC bracing methods fail to provide a workable or code-compliant solution for a given braced wall line or for a dwelling as a whole, consider:

- Custom engineered solutions.
- Engineered standard solutions that supplement the IRC bracing provisions and may be used repetitively (e.g., a standard construction detail).
- Code approved proprietary bracing products.

Custom Engineered Solutions

Using custom engineered bracing solutions for an entire dwelling or for a non-compliant portion of a dwelling is permitted per IRC Sections R104.10, R104.11, R301.1.3 and R602.10.10.

In general, an engineered solution must comply with accepted engineering practice using the building code resources and standards listed at the end of this guide. Accepted engineering practice may also involve use of recognized design resources such as the *Residential Structural Design Guide (HUD, 2000)* which provides data and insights beyond those found in building codes, design standards and standard textbooks (see Additional References).

Remember, though, all of these sources of “accepted engineering practice” do not replace the need for practical engineering judgment in designing a wall bracing solution for a conventional wood frame dwelling. In part, this is because the structural performance of conventional light-frame construction - particularly at a system level - is not easily or accurately predicted by current conventions of engineering theory and analysis (*Crandell and Kochkin, 2003*). Therefore, it is important to employ a design professional or engineer who has a practical understanding of residential wood frame construction and structural design.

Engineered Standard Solutions (Examples & Concepts)

In many cases, an engineered bracing solution may meet both the intent of the building code and addresses a common bracing design issue with a solution that can be used repetitively on different plans with similar conditions.



Use of these example solutions may require local building official approval or the services of a Design Professional.

Partial Credit for Narrow Braced Wall Panels - Many building plans include one or more braced wall lines with braced wall panels that are not compliant with the prescribed brace wall panel width limits in the IRC (see *Table 1*). However, these braced wall panels do contribute to wall bracing and may be assigned partial credit as shown in *Table 4*. In these cases, the effective braced wall panel length is used in lieu of the actual braced wall panel length in determining compliance with required bracing amounts. Although not specifically IRC-approved, this approach gives “partial credit” for braced wall panels between 24” and 48” wide.

Table 4: Effective Brace Lengths for Brace Segments <48"
(Brace Method 2-4, 6-8)

Actual Brace Wall Panel Length (inches)	Effective Brace Wall Panel Length (inches)
48	48
42	37
36	27
30	19
24	12

Note:

Effective lengths are based on relative difference in overturning tension force at the base of the panel in comparison to a standard 48" wide braced wall panel.

Interior Partition Walls as a Bracing Method - Because standard interior partition walls are constructed in much the same manner as Method 5 wall bracing (except for the fastening schedule), these types of interior walls can be considered for their contribution to the bracing of a residential building. However, standard interior finishes on the inside face of exterior braced wall lines should not be additionally considered because their contribution is already factored into the prescribed bracing amounts in the IRC.

A double-sided interior partition wall with a minimum 1/2" gypsum wall board on both faces and using standard fastening per IRC Table R702.3.5 provides approximately one-half the bracing strength of Method 5 with panels on 'both sides'. As a rule of thumb, interior partition walls with segments of at least 48" width and a minimum 1/2" thick gypsum panels on both wall faces may be counted as a braced wall line (i.e., Method 5 with gypsum panels on one side is approximately equivalent to a standard interior partition wall with gypsum panels on both sides).

For example, if an interior braced wall line is required or optionally used, it may be designed using standard interior partition walls with 1/2" GWB on both sides per IRC Table R702.3.5 and the required amount of bracing (length of GWB panels) can be determined by using the column for "Method 5 (one side)" in *Table 3a* or *Table 3b*.

Reduce Bracing Amount for Braced Wall Line Spacing <35' - The amount of required bracing increases proportionally when the braced wall line spacing is greater than 35' up to a maximum of 50'. (See *Table 3a* or *Table 3b*) Similarly, the same principle may be used to proportionately reduce bracing amounts when the braced wall line spacing is less than 35'.

For example, when the braced wall line spacing 'D' is less than 35', multiply the bracing amount for 35' braced wall line spacing in *Table 3a* or *Table 3b* by D/35.



Bracing amounts should not be reduced to less than 16% of braced wall line length and must still meet braced wall panel location requirements.

Altering Braced Wall Panel Location Requirements - The IRC requirement to locate braced wall panels no further than 12.5' from the ends of braced wall lines and no more than 25' OC comes from a traditional practice (i.e., the 25' OC requirement was intended for high seismic regions in the 1958 HUD *Minimum Property Standards* where additional bracing is required at more than just at the ends of exterior wall lines). However, design calculations show that panels can be spaced further apart - provided the wall top plate and its splices are designed to collect in-plane or parallel shear (racking forces) along the top

of the wall and transfer them to the braced wall panels. In fact, a system of elements (including more than just the top plate) transfers these forces along wall lines and into intermittently spaced braced wall panels. This consideration and a general approach to designing collectors (e.g., top plates and top plate splices) are presented in the *Residential Structural Design Guide* (HUD, 2000). As a result, in specific cases, braced wall panels can be designed to begin further than 12.5' from the ends of a braced wall line and spaced greater than 25' OC along a braced wall line provided that:

- o an adequate overall bracing amount is maintained for a braced wall line and
- o the collector (top plate) is designed to accommodate the additional in-plane tension or compression forces that result from a wider spacing of braced wall panels. Typically this affects the number or size of fasteners used in lap-splices of the top plate.

Allowance for Bracing Transfer - Buildings that are adequately braced on three sides are stable against lateral loads due to the ability of racking forces (shear) to be redistributed by torsional (twisting) response of the building (see *Figure 9b and d*). Therefore, bracing amounts for braced wall lines on the longer side of a dwelling or on a garage may be reduced to the minimum required in *Table 3a* or *Table 3b* (e.g., 16%) or less. In these cases, the amount of bracing equivalent to that which was removed must be placed (transferred to) the opposite side of the building. This approach provides an easy and practical solution when addressing bracing of garages where little or no bracing is provided at the garage opening wall line, but ample space is provided for additional bracing on the rear wall as well as the side walls of the garage.

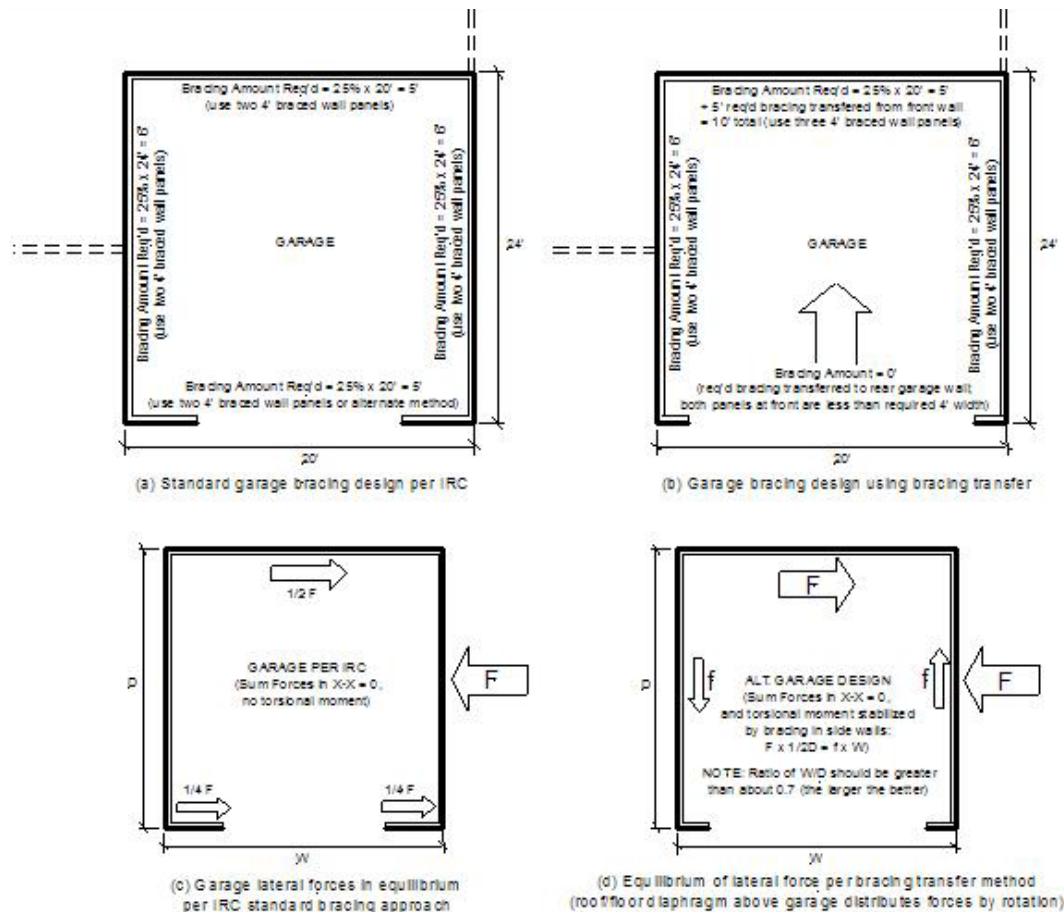

Figure 9: Bracing Transfer

Allowance for > ±4' limit for Offsets within a Braced Wall Line - The 4' offset limit for braced wall lines in the IRC is not based on analysis or specific data. However, data from the Northridge earthquake, as well as whole-building tests, have demonstrated that the existing 4' offset limit is conservative (See Additional References).

For example, whole building tests have shown the ability of conventional homes to distribute loads adequately to braced wall lines that have offsets of 6' (HUD, 2001). In addition, no measurable difference in performance of homes with and without 4' offsets in braced wall lines was observed in carefully studied damage statistics for single family detached homes (HUD, 1999). Use engineering judgment with applying the existing 4' offset limit.

Proprietary Bracing Products

A variety of proprietary pre-fabricated braced wall panel or frame products are available that provide efficient solutions where racking loads are high and wall space is limited as per IRC Section R602.10.6. (See Additional Resources) Many are “in-wall” systems that fit within the thickness of wall framing and allow the use of a continuous thickness of insulating foam sheathing on all wall surfaces (similar to Method 1). Typically these types of braces are more expensive than “site-built” braced wall panels and require a greater level of coordination between foundation and framing phases. In addition, engineering support may be required, especially for anchorage and foundation design. In some localities, special inspections may be required.

For these proprietary products, minimum braced panel or frame widths range from 12” to 24” or more; allowable racking (shear) loads range from under 1,000 lbs to over 10,000 lbs depending on width and type of panel construction. In some cases, these products can be directly substituted for braced wall panels required in the IRC provided the proprietary panel has at least equivalent allowable shear strength (e.g., not less than 800 lbs rated shear capacity).



Contact the proprietary brace manufacturer for additional guidance and requirements.

Section 4: Wall Bracing Options for Foam-Sheathed Walls

When used properly, various wall bracing methods included in IRC Section R602.10 provide equivalent and code-compliant minimum performance. Being able to select different bracing methods - even along the same wall line - may impact other design decisions of the wall such as:

- Support of interior and exterior finishes
- Energy efficiency
- Moisture resistance
- Resistance to structural loads
- Architectural appearance and function (e.g., size and distribution of windows and doors, interior and exterior wall layout, etc.).

In addition, deciding what bracing method to use may also be necessary to optimize conflicting design objectives (e.g., minimizing cost, maximizing energy efficiency, maximizing window openings, maximize moisture control and durability, etc.).

Why Use Foam Sheathing?

The advantages of using insulated foam sheathings are well known and highlighted in *Table 5*. Foam sheathing serves many different functions in the wall design - insulation, water resistant barrier, backer board, etc - so it is important that the designer is aware that bracing requirements are only one function of the wall and other functions should be considered. For example, with energy costs high, the insulation value of foam sheathings makes it an ideal wall component and racking requirements can be easily addressed to augment the non-structural insulation sheathing.

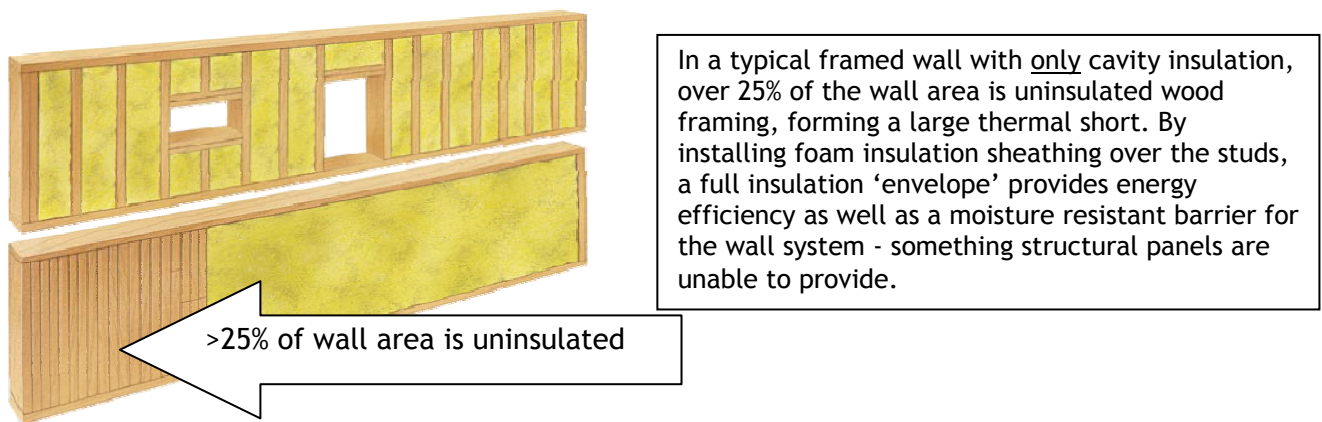

Remember that bigger does not necessarily mean stronger; using larger studs (e.g., 2 x 6 vs. 2 x 4) does not affect or improve resistance to lateral loads. Try to think of the wall as a system where all functions need to be addressed and optimized.

Although foam sheathing is NOT an acceptable wall bracing material on its own, the additional benefits - especially for energy efficiency and moisture resistance - and the range of available or compatible bracing techniques - makes it a preferred choice in many wall configurations.

Table 5: Functions of Foam Sheathing in Above-Grade Residential Walls

Wall Function *	Foam Sheathing Role in Wall Function	IRC Code Reference ⁴	Comments
Provide strength and rigidity	Use with approved bracing methods Use with approved load path methods	R602.10 Table 602.3 (1), R802.10.5, R802.11.1	All sheathings must comply with structural requirements of the code, as detailed in this document.
Control heat flow	Reduces thermal shorts by insulating the entire wall surface, not just between studs	Chapter 11	Since 25% of the exterior wall surface can be wood framing, insulating only in the stud cavity is like leaving one whole wall uninsulated. Foam sheathing insulates the whole wall. May be able to meet energy requirements with lower cost 2x4 wall instead of 2x6 wall.
Control air flow	Fasten foam sheathing directly to studs to reduce air infiltration through the wall; better than housewrap over OSB sheathing.	N1102.1.10	Because foam sheathing conforms to irregularities on the surface of framing lumber, it forms a gasket that reduces air infiltration through the wall.
Control rain penetration	Can qualify as a water resistive barrier	R703.2, Table 703.4	Foam sheathing that has passed AC 71 qualifies as an approved water resistive barrier and does not need to be covered with housewrap.
Control water vapor flow	Can control water vapor flow through the wall and reduce the potential for condensation in the wall	R318	Water vapor becomes a problem in walls when it condenses into liquid water. Foam sheathing reduces the potential for condensation in walls by controlling the relative humidity in the wall and/or controlling the temperature in the wall.

* from Hutcheon

Meeting Energy Code Requirements

Always confirm that applicable energy code requirements are being met, regardless of the type of bracing method used. In many locations, installing insulated foam sheathing will easily provide the required wall R-values. For example, the IECC 2003 Energy Code and the 2004 IRC Supplement (Table N1102.1, footnote g), requires that where structural sheathing covers more than 25% of the opaque exterior wall (excluding any openings), an R2 insulated sheathing (minimum) is required to minimize thermal shorts, depending on the building’s geographic location.

⁴ In accordance with IRC 2003.

Which Bracing Method(s) to use with Foam Sheathing?

As summarized in **Table 6**, different bracing methods can be used to construct code-compliant, foam-sheathed walls. Remember that more than one bracing method can be used on a dwelling - or even within a braced wall line.

Table 6: Common IRC Wall Bracing Methods using Foam Sheathing
(based on IRC Section R602.10.2, Section R602.10.3-6)

Bracing Method ⁵	Braced Wall Panel Minimum Width	Foam Sheathing Applications
METHOD 1: 1x4 wood let-in brace or approved metal brace	Brace angle must be at least 45 degrees and not more than 60 degrees from horizontal.	<i>Pros:</i> Use foam sheathing continuously and of uniform thickness on exterior of building. <i>Cons:</i> May not be applicable to braced wall lines with substantial wall opening amounts for windows and doors or on the first floor of a three story structure
METHOD 3: Wood structural panels METHOD 4: Fiberboard	48" minimum	<i>Pros:</i> Use ½" foam sheathing over brace panels and 1" foam in-between braced wall panels for improved energy efficiency. See Energy Code Requirements, page 23 for additional details. <i>Cons:</i> Braced wall panels less than 48" wide do not count toward required bracing amounts so these methods may not be applicable to braced wall lines with substantial wall opening amounts for windows and doors.
METHOD 5: Gypsum board	96" minimum (single side) 48" minimum (both sides)	<i>Pros:</i> Use single side, interior application with exterior foam sheathing on wall lines where minimum 96" lengths are uninterrupted by openings (e.g., end walls). Use on interior braced wall lines (both sides) to meet braced wall line spacing limits or to reduce bracing amount required on parallel exterior braced wall lines. <i>Cons:</i> Must attach gypsum panels using more stringent fastening schedule than standard for interior finishes. Single side applications may not be applicable to walls with substantial wall opening amounts for windows and doors.
Continuous wood structural panel sheathing (R602.10.5)	24" and greater - see <i>Table 2</i> .	<i>Pros:</i> Place foam sheathing over wood structural panels for both insulation and as a weather-resistant barrier behind siding when properly detailed (taped joints, flashed at wall system penetrations); in cold climates, foam sheathing can serve to protect wood sheathing and framing from condensation by creating a "warm wall". <i>Cons:</i> Size and install siding fasteners to adequately penetrate studs through exterior sheathing layers. Consider drainable siding installations, especially in wind-driven rain climates (e.g., wood or cement lap siding on furring, vinyl siding, brick veneer, etc.). Must still comply with bracing percentage and width of Method 3.
Alternate braced wall panels (R602.10.6)	32" minimum	<i>Pros:</i> Allows for slightly narrower panel than typical 48" braced wall panel but otherwise similar to Method 3 in terms of foam sheathing applications. <i>Cons:</i> Requires additional framing expense for hold-down brackets and additional fastening of sheathing.

Because a variety of bracing methods can be used - even along one wall - optimizing the method is critical, as shown in *Figure 10*.

⁵ Refer to IRC Section R602.10.1-4 for complete installation requirements, material thickness requirements and details for each bracing method.

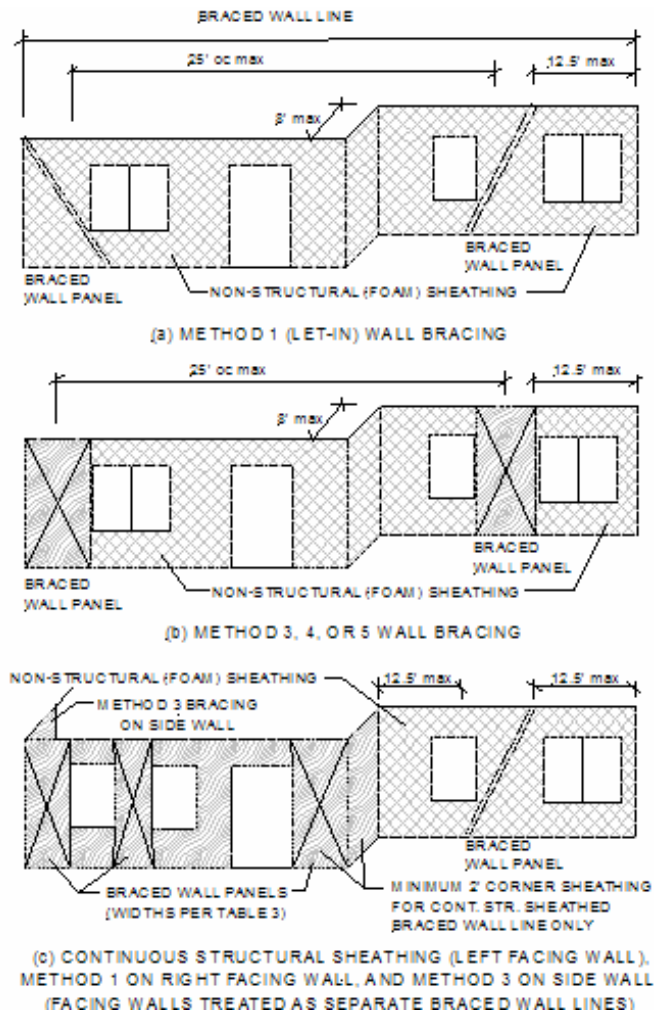

Figure 10: Illustration of Bracing Methods with Foam Sheathing

Examples

Generally, when using a foam-sheathed wall assembly, the following common bracing approaches are used to maximize the benefits of foam sheathing at minimum cost while still complying with wall bracing requirements. These approaches can be applied to an entire building or, for more complex building plans, apply to different exterior wall lines.

Example 1: Continuous Foam Sheathing with Internal or Inset Wall Bracing (Method 1)

Benefit	Installation Details
<ul style="list-style-type: none"> • Maximizes energy efficiency • Minimizes cost • Allows use of 2x4 vs. 2x6 studs • Allows use of less expensive normal density batt insulation to meet energy code (e.g., in northern climates where required wall insulation exceeds R13). • Foam sheathing serves multiple functions (siding backer, air-barrier, and water-resistive barrier). 	<ul style="list-style-type: none"> • Apply foam sheathing of selected thickness (commonly ½” minimum and up to as much as 1 ½” or more) continuously over the entire framed wall area. • Detail foam to act as an air and/or water-resistive barrier (e.g., joints taped and/or seams flashed at window and door edges) and to replace building paper or wrap under siding. • Use bracing methods that are inset or “internal” to the wall framing, such as the traditional Method 1 wood let-in bracing or code-approved equivalent metal braces (See Additional References).

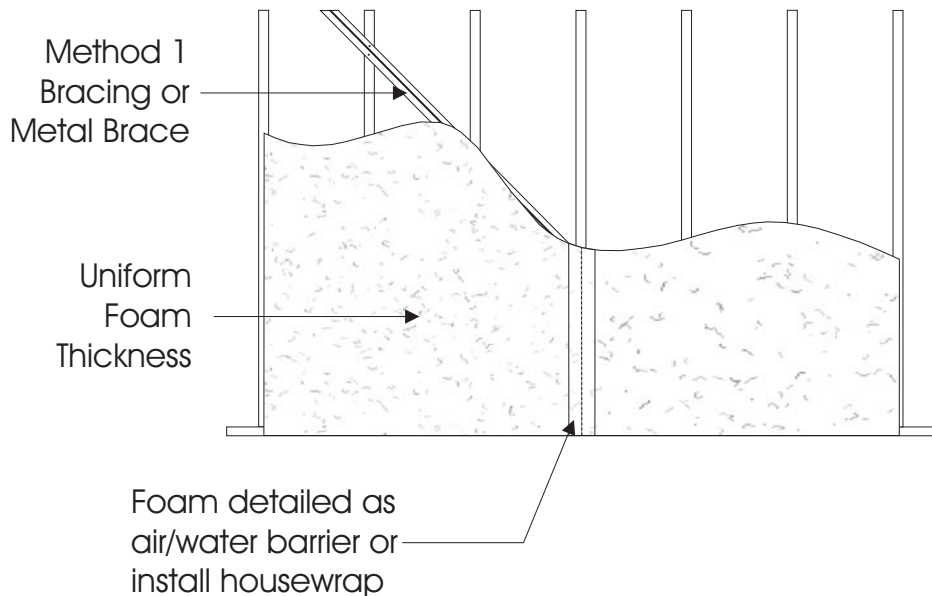

Example 2: Continuous Foam Sheathing over Continuous Bracing Panels

Benefit	Installation Details
<ul style="list-style-type: none"> • Maximizes energy efficiency • Provides a thermal blanket to reduce thermal short-circuiting through studs • Reduces moisture condensation during cooler months that may occur with non-insulating exterior sheathing in mixed and cold climates 	<ul style="list-style-type: none"> • Place foam-sheathing directly over a fully or continuously sheathed wall, using a code-compliant structural panel ('over sheathing'). • Use OSB or plywood panels, fiberboard sheathing (Method 4) or other proprietary products (e.g., laminated fibrous board sheathing materials). • Detail foam to act as an air and/or water-resistant barrier (e.g., joints taped and/or seams flashed at window and door edges) and to replace building paper or wrap under siding.

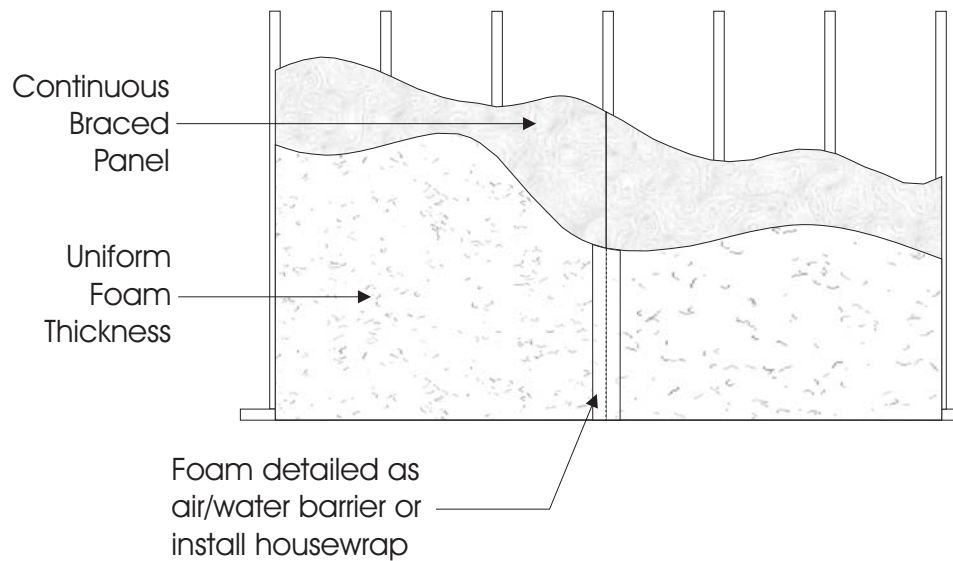

Example 3: *Continuous, Variable Thickness Foam Sheathing over Intermittent Brace Panels*

Benefit	Installation Details
<ul style="list-style-type: none"> • Maximizes energy efficiency • Provides a thermal blanket to reduce thermal short-circuiting through studs • Reduces moisture condensation during cooler months that may occur with non-insulating exterior sheathing in mixed and cold climates] 	<ul style="list-style-type: none"> • Place foam-sheathing directly over intermittent brace panels in the braced wall line (e.g., install 1/2" foam <u>over</u> brace panel and 1" foam <u>between</u> brace panel). • Detail foam to act as an air and/or water-resistant barrier (e.g., joints taped and/or seams flashed at window and door edges) and to replace building paper or wrap under siding.

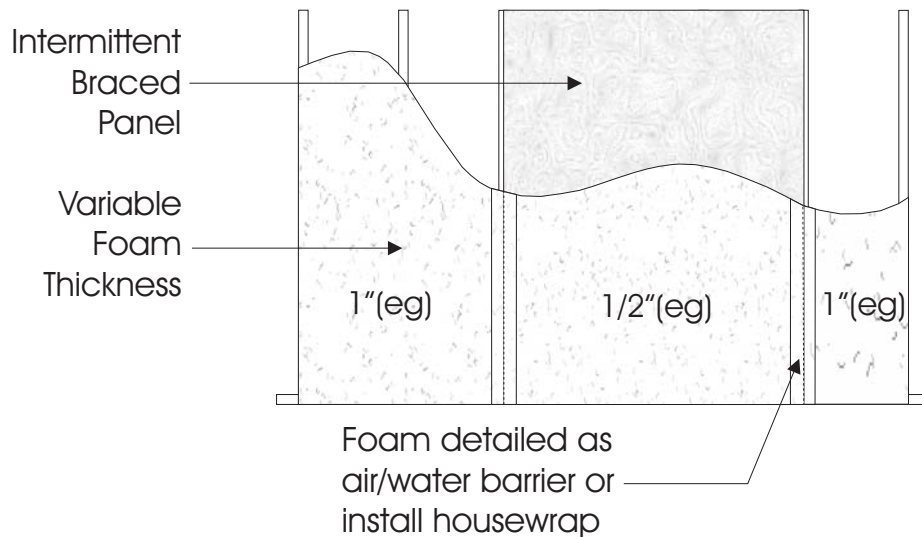

Example 4: Foam Sheathing Only Between Intermittent Brace Panels

Benefit	Installation Details
<ul style="list-style-type: none"> • Provides high insulation value to meet or exceed energy code requirements • If structural braced panels comprise 25% or less of the wall square footage considered to be fully sheathed building structure 	<ul style="list-style-type: none"> • Install ½” or 7/16” foam insulation sheathing to flush wall line to 7/16” OSB or plywood panels. • Cover all wood panels with a moisture resistant barrier (housewrap). • Apply foam sheathing over gable end walls. NOTE: Gable end walls are not included in the wall bracing requirements and foam insulation sheathing can be utilized

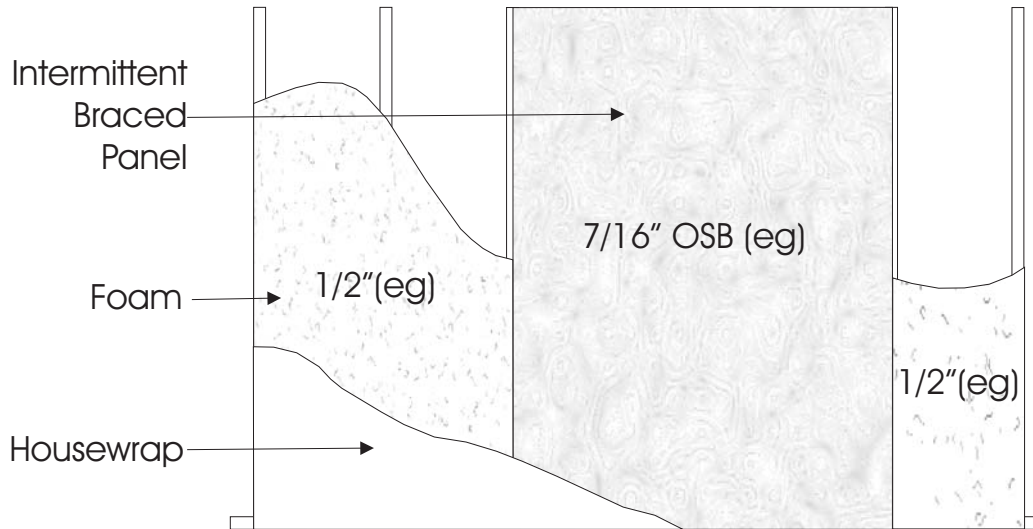

Interfaces between Materials

Because many different types of bracing and materials may be used on a single dwelling, care must be taken at these interfaces. For example, if one wall used foam sheathing with metal bracing and another wall uses wood sheathing with housewrap, the designer has three options:

1. Continue the housewrap over the foam sheathing and tape all seams securely.
2. Wrap the housewrap at least 6” over the foam insulation and securely tape the housewrap to the foam sheathing.
3. Continue the foam sheathing over the wood sheathing (use ½” or 7/16” foam sheathing) called “oversheathing” and detail the foam sheathing as the water-resistive barrier using tape at the joints.

Additional References

Need more information? Here is a partial list of resources:

Design Tools and Resources:

Residential Structural Design Guide - 2000 Edition (HUD, 2000) - available as free download at www.huduser.org

Chapters 16 and 23 of the *International Building Code* (ICC, 2006) - www.iccsafe.org

Minimum Design Loads for Buildings and Other Structures (ASCE, 2005) - www.asce.org

National Design Specification for Wood Construction (AF&PA, 2005) - www.awc.org

Special Design Provisions for Wind and Seismic (AF&PA, 2005) - www.awc.org

Evaluation of Housing Performance and Seismic Design Implications in the Northridge Earthquake. U.S. Department of Housing and Urban Development, Washington, DC. 1999. (www.huduser.org)

Whole Structure Testing and Analysis of a Light-Frame Wood Building (Three Reports). U.S. Department of Housing and Urban Development, Washington, DC. 2001. (www.huduser.org)

The Performance of Perforated Shear Walls with Narrow Wall Segments, Reduced Base Restraint, and Alternative Framing Methods. U.S. Department of Housing and Urban Development, Washington, DC. 1998. (www.huduser.org)

Crandell, J.H. and Kochkin, V., "Common Engineering Issues in Conventional Construction," *Wood Design Focus*, Vol. 13, No. 3, Forest Products Society, Madison, WI. Fall 2003

Metal Bracing:

- T wall braces (www.tamlyn.com)
- L and T wall braces (www.uspconnectors.com)

Proprietary Bracing Products:

- Inset Wood Shear Panel (www.tamlyn.com)
- Strong-Wall Panels (www.strongtie.com)
- Hardy Frame (www.hardyframe.com)
- Shear Max Panels (www.shearmax.com)
- TJ Shear Panels (www.ilevel.com)

Foam Sheathing Coalition (FSC)
4223 Dale Boulevard
Woodbridge, VA 22193
Tel: 800.978.9772

*Be sure to visit the FSC Website www.foamsheathing.org (available Oct. '06)
for a downloadable copy of this Guide and Supplement and for other important information.*

Alliance for the
Polyurethanes Industry
(API)
1300 Wilson Boulevard
Arlington, VA 22209
Tel: 703.741.5103
Fax: 703.741.5655
www.polyurethane.org

Extruded Polystyrene Foam
Assn. (XPSA)
4223 Dale Boulevard
Woodbridge, VA 22193
Tel: 703.730.0062
Fax: 703.583.5860
www.xpsa.com

Polyisocyanurate Insulation
Manufacturers Assn. (PIMA)
7315 Wisconsin Avenue
Suite 400E
Bethesda, MD 20814
Tel: 301.654.0000
Fax: 301.951.8401
www.polyiso.org

Disclaimer

The information contained herein is provided for educational purposes only. FSC does not assume any warranty, expressed or implied or assumes any liability.

Always consult with a design professional and/or local building code officials for additional support.